

Data sheet

Solenoid Valve

Types EVR 2 – 40 NC/NO

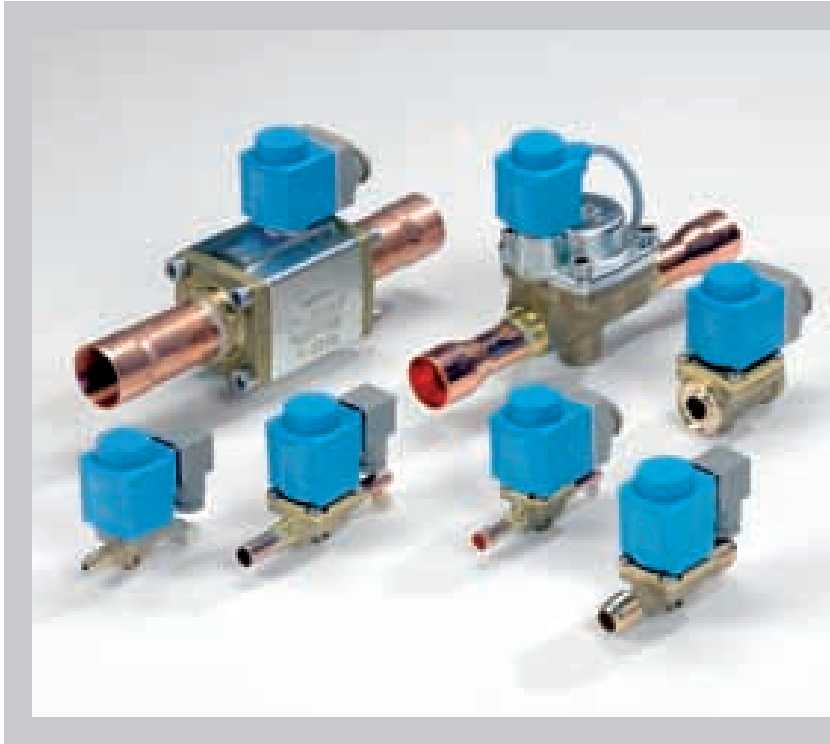

EVR is a direct or servo operated solenoid valve for liquid, suction, and hot gas lines with fluorinated refrigerants.

EVR valves are supplied complete or as separate components, i.e. valve body, coil and flanges, if required, can be ordered separately.

Features

- Complete range of solenoid valves for refrigeration, freezing and air conditioning plant
- Supplied in versions normally closed (NC) and normally open (NO) with de-energized coil
- Wide choice of coils for a.c. and d.c.
- Suitable for all fluorinated refrigerants
- Designed for media temperatures up to 105 °C
- MOPD up to 25 bar with 12 W coil
- Flare connections up to $\frac{5}{8}$ in.
- Solder connections up to 2 $\frac{1}{8}$ in.
- Extended ends on solder versions make the installation easy. It is not necessary to dismantle the valve when soldering in.
- Available in flare, solder and flange connection versions

Approvals

- | | |
|---|---|
| Det norske Veritas, DNV | Polski Rejestr Statków, Polen |
| Pressure Equipment Directive (PED) 97/23/EC | Maritime Register of Shipping, MRS |
| Low Voltage Directive (LVD) 2006/95/EC | Versions with UL approval can be supplied to order. |

Technical data

Refrigerants
R22/R407C, R404A/R507, R410A, R134a, R407A,
R23. For other refrigerants,
please contact Danfoss.

Temperature of medium
-40 – 105 °C with 10 W or 12 W coil.
Max. 130 °C during defrosting.

Ambient temperature and enclosure for coil.
See separate technical brochure for coils.

Type	Opening differential pressure with standard coil Δp [bar]				Temperature of medium [°C]	Max. working pressure P_s [bar]	k_v value ¹⁾ [m ³ /h]
	Min.	Max. (= MOPD) liquid ²⁾					
		10 W a. c.	12 W a. c.	20 W d. c.			
EVR 2	0.00	25	—	18	-40 – 105	45.2	0.16
EVR 3	0.00	21	25	18	-40 – 105	45.2	0.27
EVR 6	0.05	21	25	18	-40 – 105	45.2	0.80
EVR 6 NO	0.05	21	21	21	-40 – 105	45.2	0.80
EVR 10	0.05	21	25	18	-40 – 105	35.0	1.90
EVR 10 NO	0.05	21	21	21	-40 – 105	35.0	1.90
EVR 15	0.05	21	25	18	-40 – 105	32.0	2.60
EVR 15 NO	0.05	21	21	21	-40 – 105	32.0	2.60
EVR 20 with a.c. coil	0.05	21	25	13	-40 – 105	32.0	5.00
EVR 20 with d.c. coil	0.05	—	—	16	-40 – 105	32.0	5.00
EVR 20 NO	0.05	19	19	19	-40 – 105	32.0	5.00
EVR 22	0.05	21	25	13	-40 – 105	32.0	6.00
EVR 22 NO	0.05	19	19	19	-40 – 105	32.0	6.00
EVR 25 ³⁾	0.20	21	25	18	-40 – 105	32.0	10.00
EVR 32 ³⁾	0.20	21	25	18	-40 – 105	32.0	16.00
EVR 40 ³⁾	0.20	21	25	18	-40 – 105	32.0	25.00

¹⁾The k_v value is the water flow in [m³/h] at a pressure drop across valve of 1 bar, $\rho = 1000 \text{ kg/m}^3$.

³⁾Min. diff. pressure 0.07 bar is needed to stay open.

²⁾MOPD (Max. Opening Pressure Differential) for media in gas form is approx. 1 bar greater.

Type	Rated capacity [kW]								
	Liquid			Suction vapour			Hot gas		
	R22/R407C	R134a	R404A/R507	R22/R407C	R134a	R404A/R507	R22/R407C	R134a	R404A/R507
EVR 2	3.20	2.90	2.20	—	—	—	1.50	1.20	1.20
EVR 3	5.40	5.00	3.80	—	—	—	2.50	2.00	2.00
EVR 6	16.10	14.80	11.20	1.80	1.30	1.60	7.40	5.90	6.00
EVR 10	38.20	35.30	26.70	4.30	3.10	3.90	17.50	13.90	14.30
EVR 15	52.30	48.30	36.50	5.90	4.20	5.30	24.00	19.00	19.60
EVR 20	101.00	92.80	70.30	11.40	8.10	10.20	46.20	36.60	37.70
EVR 22	121.00	111.00	84.30	13.70	9.70	12.20	55.40	43.90	45.20
EVR 25	201.00	186.00	141.00	22.80	16.30	20.40	92.30	73.20	75.30
EVR 32	322.00	297.00	225.00	36.50	26.10	32.60	148.00	117.00	120.00
EVR 40	503.00	464.00	351.00	57.00	40.80	51.00	231.00	183.00	188.00

Rated liquid and suction vapour capacity is based on evaporating temperature $t_e = -10 \text{ }^\circ\text{C}$, liquid temperature ahead of valve $t_l = 25 \text{ }^\circ\text{C}$, pressure drop in valve $\Delta p = 0.15 \text{ bar}$.

Rated hot gas capacity is based on condensing temperature $t_c = 40 \text{ }^\circ\text{C}$, pressure drop across valve $\Delta p = 0.8 \text{ bar}$, hot gas temperature $t_h = 65 \text{ }^\circ\text{C}$, and subcooling of refrigerant $\Delta t_{sub} = 4 \text{ K}$.

Ordering
(continued)

Separate valve bodies, normally closed (NC)

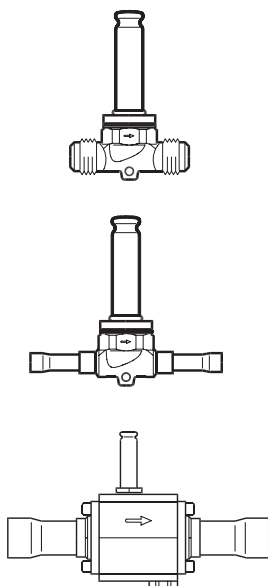

Type	Option coil type	Connection		Code no. Valve body without coil				
				Flare ¹⁾		Solder ODF		
		[in.]	[mm]	[in./mm]	[in.]	[mm]	With manual operation	Without manual operation
EVR 2	a.c.	1/4	6	032F8056	032F1201	032F1202	—	—
EVR 3	a.c. / d.c.	1/4	6	032F8107	032F1206	032F1207	—	—
	a.c. / d.c.	3/8	10	032F8116	032F1204	032F1208	—	—
EVR 6	a.c. / d.c.	3/8	10	032F8072	032F1212	032F1213	—	—
	a.c. / d.c.	1/2	12	032F8079	032F1209	032F1236	—	—
EVR 10	a.c. / d.c.	1/2	12	032F8095	032F1217	032F1218	—	—
	a.c. / d.c.	5/8	16	032F8098	032F1214	032F1214	—	—
EVR 15	a.c. / d.c.	5/8	16	032F8101	032F1228	032F1228	—	—
	a.c. / d.c.	5/8	16	032F8100 ²⁾	—	—	032F1227	—
	a.c. / d.c.	7/8	22	—	032F1225	032F1225	—	—
EVR 20	a.c.	7/8	22	—	032F1240	032F1240	—	—
	a.c.	7/8	22	—	—	—	032F1254	—
	a.c.	1 1/8	28	—	032F1244	032F1245	—	—
	d.c.	7/8	22	—	032F1264	032F1264	—	—
	d.c.	7/8	22	—	—	—	032F1274	—
EVR 22	a.c.	1 3/8	35	—	032F3267	032F3267	—	—
EVR 25	a.c. / d.c.	1 1/8	—	—	—	—	032F2200	032F2201
	a.c. / d.c.	—	28	—	—	—	032F2205	032F2206
	a.c. / d.c.	1 3/8	35	—	—	—	032F2207	032F2208
EVR 32	a.c. / d.c.	1 3/8	35	—	—	—	042H1105	042H1106
	a.c. / d.c.	1 5/8	—	—	—	—	042H1103	042H1104
	a.c. / d.c.	—	42	—	—	—	042H1107	042H1108
EVR 40	a.c. / d.c.	1 5/8	—	—	—	—	042H1109	042H1110
	a.c. / d.c.	—	42	—	—	—	042H1113	042H1114
	a.c. / d.c.	2 1/8	54	—	—	—	042H1111	042H1112

Separate valve bodies, normally open (NO) ³⁾

Type	Option coil type	Connection		Code no. Valve body without coil ³⁾			
				Flare ¹⁾		Solder ODF	
		[in.]	[mm]	[in.]	[mm]	[in.]	[mm]
EVR 6	a.c. / d.c.	3/8	10	032F8085	032F8085	032F1290	032F1295
EVR 10	a.c. / d.c.	1/2	12	032F8090	032F8090	032F1291	032F1296
EVR 15	a.c. / d.c.	5/8	16	032F8099	032F8099	032F1299	032F1299
	a.c. / d.c.	7/8	22	—	—	032F3270	032F3270
EVR 20	a.c. / d.c.	7/8	22	—	—	032F1260	032F1260
	a.c. / d.c.	1 1/8	28	—	—	032F1269	032F1279
EVR 22	a.c.	1 3/8	35	—	—	032F3268	032F3268

¹⁾ Valve bodies are supplied without flare nuts.
Separate flare nuts:
– 1/4 in. or 6 mm, code no. **011L1101**
– 3/8 in. or 10 mm, code no. **011L1135**
– 1/2 in. or 12 mm, code no. **011L1103**
– 5/8 in. or 16 mm, code no. **011L1167**

²⁾ With manual operation.

³⁾ The normal range of coils can be used for the NO valves, with the exception of the double frequency versions of 110 V, 50/60 Hz and 220 V, 50/60 Hz.

See separate technical brochure for coils.

Ordering
(continued)

Separate valve bodies, normally closed (NC)

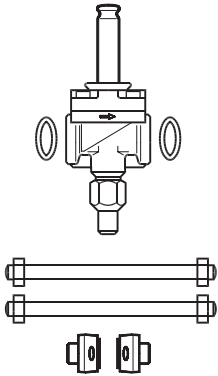

Type	Option coil type	Connection	Code no. Valve body + gaskets + bolts; without coil and flanges	
			With manual operation	Without manual operation
EVR 15	a.c. / d.c.	Flanges	032F1234	032F1224
EVR 20	a.c.	Flanges	032F1253	032F1243
	d.c.	Flanges	032F1273	032F1263

See separate technical brochure for coils.

Flange sets

Valve type	Connection		Code no.		
			Solder		Weid
	[in.]	[mm]	[in.]	[mm]	[in.]
EVR 15	1/2	—	—	—	027N1115
	5/8	16	027L1117	027L1116	—
	3/4	—	—	—	027N1120
	7/8	22	027L1123	027L1122	—
EVR 20	3/4	—	—	—	027N1220
	7/8	22	027L1223	027L1222	—
	1	—	—	—	027N1225
	1 1/8	28	027L1229	027L1228	—

Example

EVR 15 without manual operation,
code no. **032F1224**

+ coil with terminal box, 220 V, 50 Hz,
code no. **018F6701**

1/2 in. weld flange set,
code no. **027N1115**

See separate technical brochure for coils.

Accessories

Description	Code no.
Mounting bracket for EVR 2, EVR 3, EVR 6 and EVR 10	032F0197
Strainer FA for direct mounting	See "FA"

Capacity

Liquid capacity Q_e [kW]

Type	Liquid capacity Q_e [kW] at pressure drop across valve Δp [bar]				
	0.1	0.2	0.3	0.4	0.5
R22/R407C					
EVR 2	2.6	3.7	4.6	5.3	5.9
EVR 3	4.5	6.3	7.7	8.9	9.9
EVR 6	13.1	18.6	22.8	26.3	29.4
EVR 10	31.4	44.1	54.2	62.5	69.9
EVR 15	42.7	60.3	74.1	85.5	95.7
EVR 20	82.2	116.0	143.0	165.0	184.0
EVR 22	99.0	139.0	171.0	197.0	220.0
EVR 25	165.0	232.0	285.0	329.0	368.0
EVR 32	263.0	372.0	455.0	526.0	588.0
EVR 40	411.0	581.0	712.0	822.0	919.0
R134a					
EVR 2	2.4	3.4	4.2	4.9	5.4
EVR 3	4.1	5.8	7.1	8.2	9.1
EVR 6	12.1	17.2	21.0	24.3	27.1
EVR 10	28.8	40.7	49.9	57.6	64.4
EVR 15	39.4	55.7	68.3	78.8	88.1
EVR 20	75.8	107.0	131.0	152.0	170.0
EVR 22	90.9	129.0	158.0	182.0	203.0
EVR 25	152.0	214.0	263.0	303.0	339.0
EVR 32	243.0	343.0	420.0	485.0	542.0
EVR 40	379.0	536.0	656.0	758.0	847.0

Capacities are based on:
 – liquid temperature
 $t_l = 25\text{ °C}$ ahead of valve,
 – evaporating temperature
 $t_e = -10\text{ °C}$, superheat 0 K.

Correction factors

When sizing valves, the plant capacity must be multiplied by a correction factor depending on liquid temperature t_l ahead of valve/evaporator.

When the corrected capacity is known, the selection can be made from the table.

Correction factors for liquid temperature t_l

t_l [°C]	-10	0	10	15	20	25	30	35	40	45	50
R22/R407C	0.76	0.82	0.88	0.92	0.96	1.0	1.05	1.10	1.16	1.22	1.30
R134a	0.73	0.79	0.86	0.90	0.95	1.0	1.06	1.12	1.19	1.27	1.37

Capacity
(continued)

Liquid capacity Q_e [kW]

Type	Liquid capacity Q_e [kW] at pressure drop across valve Δp [bar]				
	0.1	0.2	0.3	0.4	0.5
R404A/R507					
EVR 2	1.8	2.6	3.2	3.7	4.1
EVR 3	3.1	4.4	5.4	6.2	6.9
EVR 6	9.2	13.0	15.9	18.4	20.5
EVR 10	21.8	30.8	37.8	43.6	48.8
EVR 15	29.8	42.2	51.7	59.6	66.8
EVR 20	57.4	81.1	99.4	115.0	128.0
EVR 22	68.9	97.4	119.0	138.0	169.0
EVR 25	115.0	162.0	199.0	230.0	257.0
EVR 32	184.0	260.0	318.0	367.0	411.0
EVR 40	287.0	406.0	497.0	574.0	642.0

Capacities are based on:
 – liquid temperature $t_l = 25\text{ °C}$ ahead of valve,
 – evaporating temperature $t_e = -10\text{ °C}$, superheat 0 K.

Correction factors

When sizing valves, the plant capacity must be multiplied by a correction factor depending on liquid temperature t_l ahead of valve/evaporator.

When the corrected capacity is known, the selection can be made from the table.

Correction factors based on liquid temperature t_l

t_l [°C]	-10	0	10	15	20	25	30	35	40	45	50
R404A/R507	0.65	0.72	0.81	0.86	0.93	1.0	1.09	1.20	1.33	1.51	1.74

Capacity
(continued)

Suction vapour capacity Q_e [kW]

Type	Pressure drop Δp [bar]	Suction vapour capacity Q_e [kW] at evaporating temperature t_e [°C]					
		-40	-30	-20	-10	0	10
R22/R407C							
EVR 6	0.10	0.73	0.94	1.2	1.5	1.8	2.1
	0.15	0.87	1.1	1.4	1.8	2.2	2.6
	0.20	0.98	1.3	1.6	2.0	2.5	3.0
EVR 10	0.10	1.7	2.2	2.9	3.5	4.3	5.1
	0.15	2.1	2.7	3.4	4.3	5.2	6.2
	0.20	2.3	3.1	3.9	4.8	6.0	7.1
EVR 15	0.10	2.3	3.1	4.0	4.8	5.8	6.9
	0.15	2.8	3.7	4.7	5.9	7.1	8.5
	0.20	3.2	4.2	5.3	6.6	8.2	9.8
EVR 20	0.10	4.6	5.9	7.6	9.3	11.2	13.3
	0.15	5.4	7.1	9.1	11.4	13.9	16.7
	0.20	6.1	8.1	10.3	12.7	15.9	18.8
EVR 22	0.10	5.5	7.1	9.1	11.2	13.4	16.0
	0.15	6.5	8.5	10.7	13.7	16.4	20.0
	0.20	7.3	9.7	12.3	15.2	19.0	22.6
EVR 25	0.10	9.1	11.8	15.2	18.6	22.4	26.6
	0.15	10.9	14.2	17.9	22.8	27.4	32.6
	0.20	12.2	16.1	20.4	25.3	31.7	37.6
EVR 32	0.10	14.6	18.9	24.3	29.8	35.8	42.6
	0.15	17.4	22.7	28.8	36.5	43.8	52.2
	0.20	19.6	25.7	32.6	40.5	50.7	60.2
EVR 40	0.10	22.8	29.5	38.1	46.5	56.0	66.5
	0.15	27.2	35.4	45.0	57.0	68.6	81.5
	0.20	30.5	40.2	51.0	63.3	79.2	94.0

Capacities are based on liquid temperature $t_l = 25$ °C ahead of evaporator.

The table values refer to the evaporator capacity and are given as a function of evaporating temperature t_e and pressure drop Δp across valve.

Capacities are based on dry, saturated vapour ahead of valve.

During operation with superheated vapour ahead of valve, the capacities are reduced by 4% for each 10 K superheat.

Correction factors

When sizing valves, the evaporator capacity must be multiplied by a correction factor depending on liquid temperature t_l ahead of expansion valve.

When the corrected capacity is known, the selection can be made from the table.

t_l [°C]	-10	0	10	15	20	25	30	35	40	45	50
R22/R407C	0.76	0.82	0.88	0.92	0.96	1.0	1.05	1.10	1.16	1.22	1.30

Capacity
(continued)

Suction vapour capacity Q_e [kW]

Type	Pressure drop Δp [bar]	Suction vapour capacity Q_e [kW] at evaporating temperature t_e [°C]					
		-40	-30	-20	-10	0	10
R134a							
EVR 6	0.1	0.46	0.73	0.84	1.1	1.4	1.7
	0.15	0.53	0.87	1.0	1.3	1.7	2.0
	0.2	0.58	0.98	1.1	1.5	1.9	2.4
EVR 10	0.1	1.1	1.7	2.0	2.6	3.3	4.0
	0.15	1.3	2.1	2.4	3.1	4.0	4.9
	0.2	1.4	2.3	2.7	3.5	4.5	5.7
EVR 15	0.1	1.5	2.3	2.7	3.6	4.5	5.5
	0.15	1.7	2.8	3.3	4.2	5.5	6.7
	0.2	1.9	3.2	3.7	4.8	6.1	7.8
EVR 20	0.1	2.9	4.6	5.3	7.0	8.6	10.6
	0.15	3.3	5.4	6.3	8.1	10.6	13.0
	0.2	3.7	6.1	7.1	9.3	11.7	15.0
EVR 22	0.1	3.4	5.5	6.3	8.3	10.3	12.7
	0.15	4.0	6.5	7.5	9.7	12.7	15.5
	0.2	4.4	7.3	8.5	11.1	14.0	17.9
EVR 25	0.1	5.8	9.1	10.5	13.9	17.2	21.1
	0.15	6.6	10.9	12.5	16.3	21.1	25.9
	0.2	7.3	12.2	14.1	18.5	23.4	29.9
EVR 32	0.1	9.3	14.6	16.8	22.2	27.7	33.8
	0.15	10.6	17.4	20.0	26.1	33.8	41.4
	0.2	11.7	19.6	22.6	29.6	37.4	47.4
EVR 40	0.1	14.5	22.8	26.3	34.8	43.3	52.8
	0.15	16.5	27.2	31.3	40.8	52.8	64.8
	0.2	18.3	30.5	35.3	46.3	58.5	74.8

Capacities are based on liquid temperature $t_l = 25$ °C ahead of evaporator.

The table values refer to the evaporator capacity and are given as a function of evaporating temperature t_e and pressure drop Δp across valve.

Capacities are based on dry, saturated vapour ahead of valve.

During operation with superheated vapour ahead of valve, the capacities are reduced by 4% for each 10 K superheat.

Correction factors

When sizing valves, the evaporator capacity must be multiplied by a correction factor depending on liquid temperature t_l ahead of expansion valve.

When the corrected capacity is known, the selection can be made from the table.

Correction factors based on liquid temperature t_l

t_l [°C]	-10	0	10	15	20	25	30	35	40	45	50
R134a	0.73	0.79	0.86	0.90	0.95	1.0	1.06	1.12	1.19	1.27	1.37

Capacity
(continued)

Suction vapour capacity Q_e [kW]

Type	Pressure drop Δp [bar]	Suction vapour capacity Q_e [kW] at evaporating temperature t_e [°C]					
		-40	-30	-20	-10	0	10
R404A/R507							
EVR 6	0.1	0.62	0.8	1.1	1.3	1.6	2.0
	0.15	0.73	0.97	1.3	1.6	2.0	2.4
	0.2	0.82	1.1	1.4	1.8	2.3	2.8
EVR 10	0.1	1.5	1.9	2.5	3.2	3.9	4.7
	0.15	1.7	2.3	3.0	3.9	4.8	5.8
	0.2	2.0	2.6	3.4	4.3	5.5	6.7
EVR 15	0.1	2.0	2.6	3.5	4.3	5.3	6.4
	0.15	2.4	3.2	4.1	5.3	6.5	7.9
	0.2	2.7	3.6	4.7	5.9	7.5	9.1
EVR 20	0.1	3.9	5.0	6.7	8.3	10.2	12.3
	0.15	4.6	6.1	7.9	10.2	12.5	15.2
	0.2	5.2	6.9	9.0	11.4	14.4	17.5
EVR 22	0.1	4.6	6.0	8.0	10.0	12.2	14.8
	0.15	5.5	7.3	9.5	12.2	15.0	18.2
	0.2	6.2	8.3	10.8	13.6	17.3	21.0
EVR 25	0.1	7.7	10.1	13.3	16.6	20.4	24.6
	0.15	9.1	12.1	15.8	20.4	25.0	30.3
	0.2	10.3	13.8	18.0	22.7	28.8	35.0
EVR 32	0.1	12.3	16.2	21.3	26.6	32.6	39.4
	0.15	14.6	19.4	25.3	32.6	40.0	48.5
	0.2	16.5	22.0	28.8	36.3	46.1	56.0
EVR 40	0.1	19.3	25.3	33.3	41.5	51.0	61.5
	0.15	22.8	30.3	39.5	51.0	62.5	75.6
	0.2	25.8	34.5	45.0	56.8	72.1	87.5

Capacities are based on liquid temperature $t_l = 25$ °C ahead of evaporator.

The table values refer to the evaporator capacity and are given as a function of evaporating temperature t_e and pressure drop Δp across valve.

Capacities are based on dry, saturated vapour ahead of valve.

During operation with superheated vapour ahead of valve, the capacities are reduced by 4% for each 10 K superheat.

Correction factors

When sizing valves, the evaporator capacity must be multiplied by a correction factor depending on liquid temperature t_l ahead of expansion valve.

When the corrected capacity is known, the selection can be made from the table.

Correction factors based on liquid temperature t_l

t_l [°C]	-10	0	10	15	20	25	30	35	40	45	50
R404A/R507	0.65	0.72	0.81	0.86	0.93	1.0	1.09	1.20	1.33	1.51	1.74

Capacity
(continued)

Hot gas defrosting

With hot gas defrosting it is not normally possible to select a valve from condensing temperature t_c and evaporating temperature t_e .

This is because the pressure in the evaporator as a rule quickly rises to a value near that of the condensing pressure. It remains at this value until the defrosting is finished.

In most cases therefore, the valve will be selected from condensing temperature t_c and pressure drop Δp across the valve, as shown in the example for heat recovery.

Heat recovery

The following is given:

- Refrigerant = R22/R407C
- Evaporating temperature $t_e = -30\text{ °C}$
- Condensing temperature $t_c = 40\text{ °C}$
- Hot gas temperature ahead of valve $t_h = 85\text{ °C}$
- Heat recovery condenser yield $Q_h = 8\text{ kW}$

The capacity table for R22/R407C with $t_c = 40\text{ °C}$ gives the capacity for an EVR 10 as 8.9 kW, when pressure drop Δp is 0.2 bar.

The correction factor for $t_e = -30\text{ °C}$ is given in the table as 0.94.

The correction for hot gas temperature $t_h = 85\text{ °C}$ has been calculated as 4% which corresponds to a factor of 1.04.

Q_h must be corrected with factors found:

With $\Delta p = 0.2\text{ bar}$
is $Q_h = 8.9 \times 0.94 \times 1.04 = 8.7\text{ kW}$.

With $\Delta p = 0.1\text{ bar}$, Q_h becomes only
 $6.3 \times 0.94 \times 1.04 = 6.2\text{ kW}$.

An EVR 6 would also be able to give the required capacity, but with Δp at approx. 1 bar. The EVR 6 is therefore too small.

The EVR is so large that it is doubtful whether the necessary Δp of approx. 0.1 bar could be obtained.

An EVR 15 would therefore be too large.

Result: An EVR 10 is the correct valve for the given conditions.

Capacity
(continued)

Hot gas capacity Q_h [kW]

Type	Pressure drop across valve Δp [bar]	Evaporating temp. $t_e = -10^\circ\text{C}$. Hot gas temp. $t_h = t_c = 25^\circ\text{C}$. Subcooling $\Delta t_{\text{sub}} = 4\text{ K}$				
		Condensing temperature t_c [$^\circ\text{C}$]				
		20	30	40	50	60
R22/R407C						
EVR 2	0.1	0.47	0.50	0.53	0.54	0.55
	0.2	0.67	0.71	0.75	0.77	0.78
	0.4	0.96	1.02	1.07	1.10	1.11
	0.8	1.32	1.37	1.48	1.57	1.59
	1.6	1.87	1.99	2.08	2.16	2.19
EVR 3	0.1	0.80	0.85	0.89	0.92	0.93
	0.2	1.14	1.20	1.26	1.30	1.32
	0.4	1.63	1.72	1.80	1.85	1.87
	0.8	2.23	2.31	2.49	2.65	2.68
	1.6	3.15	3.35	3.52	3.64	3.69
EVR 6	0.1	2.4	2.5	2.6	2.7	2.8
	0.2	3.4	3.6	3.7	3.8	3.9
	0.4	4.8	5.1	5.3	5.5	5.6
	0.8	6.6	6.8	7.4	7.9	7.9
	1.6	9.3	9.9	10.4	10.8	10.9
EVR 10	0.1	5.6	6.0	6.3	6.5	6.5
	0.2	8.0	8.5	8.9	9.2	9.3
	0.4	11.4	12.1	12.7	13.0	13.2
	0.8	15.7	16.2	17.5	18.7	18.9
	1.6	22.2	23.6	24.8	25.6	26.0
EVR 15	0.1	7.7	8.2	8.6	8.8	8.9
	0.2	11.0	11.6	12.1	12.5	12.7
	0.4	15.7	16.6	17.3	17.8	18.0
	0.8	21.5	22.2	24.0	25.5	25.9
	1.6	30.3	32.3	33.9	35.0	35.5

An increase in hot gas temperature t_h of 10 K, based on $t_h = t_c = 25^\circ\text{C}$, reduces valve capacity approx. 2% and vice versa.

A change in evaporating temperature t_e changes valve capacity; see correction factor table below.

Correction factors

When sizing valves, the table value must be multiplied by a correction factor depending on evaporating temperature t_e .

Correction factors for evaporating temperature t_e

t_e [$^\circ\text{C}$]	-40	-30	-20	-10	0	10
R22/R407C	0.90	0.94	0.97	1.0	1.03	1.05

Capacity
(continued)

Hot gas capacity Q_h [kW]

Type	Pressure drop across valve Δp [bar]	Evaporating temp. $t_e = -10$ °C. Hot gas temp. $t_h = t_c = 25$ °C. Subcooling $\Delta t_{sub} = 4$ K				
		Condensing temperature t_c [°C]				
		20	30	40	50	60
R22/R407C (continued)						
EVR 20	0.1	14.8	15.7	16.5	17.0	17.2
	0.2	21.1	22.3	23.4	24.1	24.4
	0.4	30.0	31.9	33.3	34.3	34.7
	0.8	41.3	42.7	46.2	49.1	49.6
	1.6	58.3	62.1	65.2	67.4	68.4
EVR 22	0.1	17.8	18.8	19.7	20.4	20.6
	0.2	25.3	26.8	28.0	28.9	29.3
	0.4	36.1	38.3	40.0	41.2	41.6
	0.8	49.5	51.2	55.4	58.9	59.5
	1.6	70.0	74.5	78.2	80.8	82.0
EVR 25	0.1	29.6	31.4	32.9	34.0	34.4
	0.2	42.1	44.6	46.7	48.2	48.8
	0.4	60.2	63.8	66.6	68.6	69.4
	0.8	82.5	87.9	92.3	98.2	99.2
	1.6	117.0	124.0	130.0	135.0	137.0
EVR 32	0.1	47.4	50.2	52.6	54.4	55.0
	0.2	67.4	71.4	74.7	77.1	78.1
	0.4	96.3	102.0	107.0	110.0	111.0
	0.8	132.0	140.0	148.0	157.0	159.0
	1.6	187.0	199.0	209.0	216.0	219.0
EVR 40	0.1	74.0	78.5	82.3	85.0	86.0
	0.2	105.0	112.0	117.0	121.0	122.0
	0.4	151.0	159.0	167.0	172.0	174.0
	0.8	206.0	222.0	231.0	246.0	248.0
	1.6	291.0	310.0	326.0	337.0	342.0

An increase in hot gas temperature t_h of 10 K, based on $t_h = t_c = 25$ °C, reduces valve capacity approx. 2% and vice versa.

A change in evaporating temperature t_e changes valve capacity; see correction factor table below.

Correction factors

When sizing valves, the table value must be multiplied by a correction factor depending on evaporating temperature t_e .

Correction factors for evaporating temperature t_e

t_e [°C]	-40	-30	-20	-10	0	10
R22/R407C	0.90	0.94	0.97	1.0	1.03	1.05

Capacity
(continued)

Hot gas capacity Q_h [kW]

Type	Pressure drop across valve Δp [bar]	Evaporating temp. $t_e = -10$ °C. Hot gas temp. $t_h = t_c = 25$ °C. Subcooling $\Delta t_{sub} = 4$ K				
		Condensing temperature t_c [°C]				
		20	30	40	50	60
R134a						
EVR 2	0.1	0.38	0.40	0.41	0.42	0.42
	0.2	0.54	0.57	0.59	0.60	0.59
	0.4	0.74	0.82	0.84	0.86	0.85
	0.8	1.06	1.13	1.17	1.23	1.22
	1.6	1.50	1.61	1.67	1.70	1.69
EVR 3	0.1	0.64	0.67	0.70	0.71	0.71
	0.2	0.91	0.96	0.99	1.01	1.00
	0.4	1.26	1.38	1.42	1.44	1.43
	0.8	1.79	1.90	1.98	2.08	2.05
	1.6	2.57	2.72	2.82	2.88	2.8t6
EVR 6	0.1	1.88	1.99	2.07	2.11	2.09
	0.2	2.69	2.84	2.95	3.00	2.97
	0.4	3.73	4.08	4.22	4.28	4.23
	0.8	5.29	5.62	5.86	6.16	6.08
	1.6	7.61	8.05	8.37	8.52	8.46
EVR 10	0.1	4.5	4.7	4.9	5.0	5.0
	0.2	6.4	6.8	7.0	7.1	7.1
	0.4	8.9	9.7	10.0	10.2	10.1
	0.8	12.6	13.3	13.9	14.6	14.4
	1.6	18.1	19.1	19.9	20.2	20.1
EVR 15	0.1	6.1	6.5	6.7	6.7	6.8
	0.2	8.7	9.2	9.6	9.7	9.7
	0.4	12.1	13.3	13.7	13.9	13.8
	0.8	17.2	18.3	19.0	20.0	19.8
	1.6	24.8	26.2	27.2	27.7	27.5

An increase in hot gas temperature t_h of 10 K, based on $t_h = t_c = 25$ °C, reduces valve capacity approx. 2% and vice versa.

A change in evaporating temperature t_e changes valve capacity; see correction factor table below.

Correction factors

When sizing valves, the table value must be multiplied by a correction factor depending on evaporating temperature t_e .

Correction factors for evaporating temperature t_e

t_e [°C]	-40	-30	-20	-10	0	10
R134a	0.88	0.92	0.98	1.0	1.04	1.08

Capacity
(continued)

Hot gas capacity Q_h [kW]

Type	Pressure drop across valve Δp [bar]	Evaporating temp. $t_e = -10$ °C. Hot gas temp. $t_h = t_c = 25$ °C. Subcooling $\Delta t_{sub} = 4$ K				
		Condensing temperature t_c [°C]				
		20	30	40	50	60
R134a (continued)						
EVR 20	0.1	11.8	12.5	13.0	13.2	13,1
	0.2	16.8	17.8	18.4	18.7	18,6
	0.4	23.4	25.5	26.4	26.7	26,5
	0.8	33.1	35.1	36.6	38.5	38,0
	1.6	47.6	50.3	52.3	53.3	52,9
EVR 22	0.1	14.1	15.0	15.5	15.8	15,7
	0.2	20.2	21.3	22.1	22.6	22,3
	0.4	28.0	30.6	31.6	32.1	31,7
	0.8	39.7	42.2	43.9	46.2	45,6
	1.6	57.1	60.4	62.8	63.9	63,5
EVR 25	0.1	23.6	24.9	25.9	26.4	26,2
	0.2	33.6	35.5	36.8	37.4	37,1
	0.4	46.6	51.0	52.7	53.4	52,9
	0.8	66.2	70.2	73.2	77.0	76,0
	1.6	95.2	101.0	105.0	107.0	106,0
EVR 32	0.1	37.6	39.8	41.4	42.1	41,8
	0.2	53.8	56.8	58.9	59.8	59,4
	0.4	74.7	81.6	84.3	85.4	84,6
	0.8	106.0	112.0	117.0	123.0	122,0
	1.6	152.0	161.0	167.0	170.0	169,0
EVR 40	0.1	58.8	62.3	64.7	65.8	65,3
	0.2	84.1	88.8	92.1	93.5	92,8
	0.4	117.0	127.0	132.0	134.0	132,0
	0.8	166.0	176.0	183.0	192.0	190,0
	1.6	238.0	252.0	262.0	266.0	265,0

An increase in hot gas temperature t_h of 10 K, based on $t_h = t_c = 25$ °C, reduces valve capacity approx. 2% and vice versa.

A change in evaporating temperature t_e changes valve capacity; see correction factor table below.

Correction factors

When sizing valves, the table value must be multiplied by a correction factor depending on evaporating temperature t_e .

Correction factors for evaporating temperature t_e

t_e [°C]	-40	-30	-20	-10	0	10
R134A	0.88	0.92	0.98	1.0	1.04	1.08

Capacity
(continued)

Hot gas capacity Q_h [kW]

Type	Pressure drop across valve Δp bar	Evaporating temp. $t_e = -10^\circ\text{C}$. Hot gas temp. $t_h = t_c = 25^\circ\text{C}$. Subcooling $\Delta t_{\text{sub}} = 4\text{ K}$				
		Condensing temperature t_c [°C]				
		20	30	40	50	60
R404A/R507						
EVR2	0.1	0.43	0.44	0.43	0.40	0.37
	0.2	0.61	0.62	0.61	0.58	0.53
	0.4	0.87	0.87	0.87	0.82	0.75
	0.8	1.19	1.21	1.21	1.19	1.07
	1.6	1.68	1.70	1.69	1.62	1.48
EVR3	0.1	0.73	0.74	0.73	0.69	0.63
	0.2	1.03	1.04	1.03	0.98	0.89
	0.4	1.46	1.48	1.47	1.39	1.27
	0.8	2.01	2.04	2.03	2.00	1.81
	1.6	2.83	2.87	2.84	2.74	2.50
EVR6	0.1	2.16	2.18	2.15	2.05	1.86
	0.2	3.03	3.08	3.05	2.90	2.64
	0.4	4.34	4.38	4.35	4.13	3.76
	0.8	5.94	6.05	6.02	5.92	5.37
	1.6	8.37	8.52	8.43	8.10	7.40
EVR10	0.1	5.1	5.2	5.1	4.9	4.4
	0.2	7.2	7.3	7.3	6.9	6.3
	0.4	10.3	10.4	10.3	9.8	8.9
	0.8	14.1	14.4	14.3	14.1	12.8
	1.6	19.9	20.3	20.0	19.2	17.6
EVR15	0.1	7.0	7.1	7.0	6.7	6.1
	0.2	9.9	10.0	9.9	9.4	8.6
	0.4	14.1	14.3	14.2	13.4	12.2
	0.8	19.3	19.7	19.6	19.2	17.5
	1.6	27.2	27.7	27.6	26.3	24.1

An increase in hot gas temperature t_h of 10 K, based on $t_h = t_c = 25^\circ\text{C}$, reduces valve capacity approx. 2% and vice versa.

A change in evaporating temperature t_e changes valve capacity; see correction factor table below.

Correction factors

When sizing valves, the table value must be multiplied by a correction factor depending on evaporating temperature t_e .

Correction factors for evaporating temperature t_e

t_e [°C]	-40	-30	-20	-10	0	10
R404A/R507	0.86	0.88	0.93	1.0	1.03	1.07

Capacity
(continued)

Hot gas capacity Q_h [kW]

Type	Pressure drop across valve Δp bar	Evaporating temp. $t_e = -10$ °C. Hot gas temp. $t_h = t_c = 25$ °C. Subcooling $\Delta t_{sub} = 4$ K				
		Condensing temperature t_c [°C]				
		20	30	40	50	60
R404A/R507 (continued)						
EVR20	0.1	13.4	13.7	13.5	12.8	11.6
	0.2	18.9	19.2	19.1	18.2	16.5
	0.4	27.1	27.4	27.2	25.8	23.5
	0.8	37.1	37.8	37.7	37.0	33.6
	1.6	52.4	53.3	52.6	50.6	46.2
EVR22	0.1	16.1	16.4	16.1	15.4	14.0
	0.2	22.7	23.1	22.9	21.8	19.8
	0.4	32.5	32.9	32.7	31.0	28.2
	0.8	44.5	45.4	45.2	44.4	40.3
	1.6	62.8	64.0	63.2	60.8	55.5
EVR25	0.1	26.8	27.4	26.9	25.6	23.3
	0.2	37.9	38.4	38.2	36.3	33.0
	0.4	54.2	54.9	54.5	51.7	47.0
	0.8	74.2	75.6	75.3	74.0	67.2
	1.6	105.0	107.0	105.0	101.0	92.5
EVR32	0.1	43.0	43.8	43.0	40.9	37.3
	0.2	60.6	61.4	61.1	58.1	52.8
	0.4	86.7	87.8	87.2	82.7	75.2
	0.8	119.0	121.0	120.0	118.0	107.0
	1.6	167.0	171.0	168.0	162.0	148.0
EVR40	0.1	67.0	68.5	67.3	64.0	58.3
	0.2	94.8	96.0	95.5	90.8	82.5
	0.4	136.0	137.0	136.0	129.0	117.0
	0.8	186.0	189.0	188.0	185.0	168.0
	1.6	262.0	266.0	263.0	253.0	231.0

An increase in hot gas temperature t_h of 10 K, based on $t_h = t_c = 25$ °C, reduces valve capacity approx. 2% and vice versa.

A change in evaporating temperature t_e changes valve capacity; see correction factor table below.

Correction factors

When sizing valves, the table value must be multiplied by a correction factor depending on evaporating temperature t_e .

Correction factors for evaporating temperature t_e

t_e [°C]	-40	-30	-20	-10	0	10
R404A/R507	0.86	0.88	0.93	1.0	1.03	1.07

Capacity
(continued)

Hot gas capacity G_h [kg/s]

Type	Hot gas temperature t_h [°C]	Condensing temperature t_c [°C]	Hot gas capacity G_h [kg/s] at pressure drop across valve Δp [bar]								
			0.5	1	2	3	4	5	6	7	8
R22/R407C											
EVR 2	90	25	0.005	0.007	0.01	0.011	0.012	0.012	0.012	0.012	0.012
	90	35	0.006	0.009	0.011	0.013	0.014	0.015	0.015	0.015	0.015
	90	45	0.007	0.01	0.013	0.016	0.017	0.018	0.019	0.019	0.02
EVR 3	90	25	0.009	0.012	0.016	0.019	0.02	0.02	0.02	0.02	0.02
	90	35	0.01	0.014	0.019	0.022	0.024	0.025	0.026	0.026	0.026
	90	45	0.012	0.016	0.022	0.026	0.029	0.031	0.032	0.033	0.033
EVR 6	90	25	0.027	0.037	0.049	0.055	0.058	0.059	0.059	0.059	0.059
	90	35	0.031	0.043	0.057	0.067	0.072	0.075	0.077	0.077	0.077
	90	45	0.035	0.049	0.066	0.078	0.086	0.092	0.095	0.097	0.098
EVR 10	90	25	0.064	0.088	0.116	0.131	0.139	0.14	0.14	0.14	0.14
	90	35	0.074	0.102	0.137	0.158	0.172	0.179	0.182	0.182	0.182
	90	45	0.084	0.116	0.158	0.185	0.205	0.218	0.227	0.231	0.232
EVR 15	90	25	0.084	0.116	0.153	0.173	0.182	0.184	0.184	0.184	0.184
	90	35	0.097	0.134	0.18	0.208	0.226	0.236	0.239	0.239	0.239
	90	45	0.11	0.153	0.208	0.244	0.269	0.287	0.298	0.304	0.305
EVR 20	90	25	0.169	0.231	0.305	0.346	0.365	0.368	0.368	0.368	0.368
	90	35	0.194	0.267	0.359	0.416	0.452	0.472	0.478	0.478	0.478
	90	45	0.22	0.305	0.415	0.488	0.539	0.574	0.597	0.608	0.611
EVR 22	90	25	0.203	0.277	0.366	0.415	0.438	0.442	0.442	0.442	0.442
	90	35	0.279	0.32	0.431	0.499	0.542	0.566	0.574	0.574	0.574
	90	45	0.264	0.366	0.498	0.586	0.647	0.689	0.716	0.722	0.733
EVR 25	90	25	0.331	0.453	0.599	0.677	0.715	0.722	0.722	0.722	0.722
	90	35	0.38	0.524	0.704	0.816	0.886	0.925	0.938	0.938	0.938
	90	45	0.431	0.598	0.814	0.956	1.056	1.125	1.169	1.192	1.197
EVR 32	90	25	0.539	0.739	0.976	1.106	1.168	1.179	—	—	—
	90	35	0.619	0.856	1.15	1.331	1.446	1.509	1.531	—	—
	90	45	0.704	0.978	1.329	1.562	1.723	1.837	1.909	1.947	1.955
EVR 40	90	25	0.843	1.155	1.525	1.728	1.825	1.843	—	—	—
	90	35	0.968	1.338	1.798	2.08	2.26	2.358	2.393	—	—
	90	45	1.1	1.528	2.078	2.44	2.693	2.87	2.983	3.043	3.055

An increase in hot gas temperature t_h of 10 K reduces valve capacity approx. 2% and vice versa.

Capacity
(continued)

Hot gas capacity G_h [kg/s]

Type	Hot gas temperature t_h [°C]	Condensing temperature t_c [°C]	Hot gas capacity G_h [kg/s] at pressure drop across valve Δp [bar]								
			0.5	1	2	3	4	5	6	7	8
R134a											
EVR 2	60	25	0.005	0.007	0.008	0.008	0.008	—	—	—	—
	60	35	0.006	0.008	0.01	0.011	0.012	0.012	0.012	—	—
	60	45	0.007	0.009	0.012	0.014	0.015	0.015	0.015	0.015	0.015
EVR 3	60	25	0.008	0.011	0.011	0.014	0.014	—	—	—	—
	60	35	0.009	0.013	0.016	0.018	0.018	0.018	0.018	—	—
	60	45	0.01	0.016	0.02	0.023	0.025	0.025	0.025	0.025	0.025
EVR 6	60	25	0.024	0.032	0.04	0.041	0.041	—	—	—	—
	60	35	0.028	0.038	0.049	0.055	0.056	0.056	0.056	—	—
	60	45	0.032	0.045	0.059	0.068	0.072	0.073	0.073	0.073	0.073
EVR 10	60	25	0.057	0.075	0.094	0.098	0.098	—	—	—	—
	60	35	0.066	0.09	0.117	0.13	0.132	0.132	0.132	—	—
	60	45	0.076	0.107	0.141	0.161	0.17	0.172	0.172	0.172	0.172
EVR 15	60	25	0.074	0.1	0.124	0.129	0.129	—	—	—	—
	60	35	0.087	0.119	0.154	0.171	0.167	0.167	0.167	—	—
	60	45	0.1	0.14	0.185	0.212	0.223	0.225	0.225	0.225	0.225
EVR 20	60	25	0.149	0.199	0.247	0.258	0.258	—	—	—	—
	60	35	0.174	0.238	0.307	0.341	0.347	0.347	0.347	—	—
	60	45	0.2	0.28	0.37	0.423	0.447	0.452	0.452	0.452	0.452
EVR 22	60	25	0.179	0.239	0.296	0.31	0.31	—	—	—	—
	60	35	0.209	0.286	0.368	0.409	0.416	0.416	0.416	—	—
	60	45	0.24	0.336	0.444	0.508	0.536	0.542	0.542	0.542	0.542
EVR 25	60	25	0.292	0.391	0.486	0.506	0.506	—	—	—	—
	60	35	0.341	0.467	0.602	0.668	0.679	0.679	0.679	—	—
	60	45	0.393	0.549	0.725	0.83	0.876	0.885	0.885	0.885	0.885
EVR 32	60	25	0.478	0.638	0.793	0.826	0.826	—	—	—	—
	60	35	0.556	0.763	0.994	1.091	1.108	1.108	1.108	—	—
	60	45	0.641	0.897	1.197	1.354	1.432	1.446	1.446	1.446	1.446
EVR 40	60	25	0.747	0.998	1.24	1.291	1.291	—	—	—	—
	60	35	0.87	1.192	1.553	1.704	1.731	1.731	1.731	—	—
	60	45	1.002	1.402	1.87	2.117	2.237	2.259	2.259	2.259	—

An increase in hot gas temperature t_h of 10 K reduces valve capacity approx. 2% and vice versa.

Capacity
(continued)

Hot gas capacity G_h [kg/s]

Type	Hot gas temperature t_h [°C]	Condensing temperature t_c [°C]	Hot gas capacity G_h [kg/s] at pressure drop across valve Δp [bar]								
			0.5	1	2	3	4	5	6	7	8
R404A/R507											
EVR 2	60	25	0.007	0.009	0.012	0.014	0.016	0.016	0.016	0.016	0.016
	60	35	0.008	0.011	0.014	0.017	0.019	0.02	0.02	0.02	0.02
	60	45	0.009	0.012	0.016	0.019	0.021	0.024	0.025	0.025	0.025
EVR 3	60	25	0.011	0.016	0.021	0.024	0.026	0.026	0.027	0.027	0.027
	60	35	0.013	0.018	0.024	0.029	0.031	0.033	0.035	0.035	0.035
	60	45	0.015	0.02	0.028	0.032	0.037	0.039	0.041	0.043	0.043
EVR 6	60	25	0.034	0.047	0.062	0.072	0.077	0.079	0.08	0.08	0.08
	60	35	0.038	0.054	0.072	0.085	0.093	0.098	0.101	0.101	0.102
	60	45	0.043	0.061	0.082	0.097	0.108	0.116	0.122	0.126	0.128
EVR 10	60	25	0.08	0.11	0.148	0.17	0.183	0.188	0.19	0.19	0.19
	60	35	0.091	0.127	0.171	0.2	0.22	0.233	0.241	0.241	0.243
	60	45	0.102	0.143	0.194	0.23	0.257	0.277	0.288	0.3	0.303
EVR 15	60	25	0.105	0.146	0.195	0.224	0.24	0.247	0.249	0.249	0.249
	60	35	0.12	0.167	0.224	0.253	0.289	0.307	0.316	0.317	0.32
	60	45	0.135	0.189	0.225	0.303	0.339	0.365	0.38	0.393	0.399
EVR 20	60	25	0.21	0.29	0.39	0.448	0.48	0.495	0.5	0.5	0.5
	60	35	0.239	0.333	0.45	0.526	0.58	0.614	0.632	0.633	0.639
	60	45	0.27	0.375	0.51	0.606	0.677	0.729	0.76	0.785	0.799
EVR 22	60	25	0.252	0.348	0.468	0.538	0.576	0.594	0.6	0.6	0.6
	60	35	0.287	0.4	0.54	0.631	0.696	0.737	0.758	0.76	0.767
	60	45	0.324	0.45	0.612	0.727	0.812	0.875	0.912	0.942	0.959
EVR 25	60	25	0.411	0.57	0.763	0.878	0.942	0.969	0.978	0.978	0.978
	60	35	0.468	0.653	0.881	1.032	1.136	1.203	1.239	1.241	1.253
	60	45	0.529	0.734	1.0	1.188	1.326	1.43	1.49	1.539	1.566
EVR 32	60	25	0.672	0.931	1.245	1.432	1.539	1.581	1.581	1.581	1.581
	60	35	0.765	1.069	1.436	1.686	1.854	1.964	2.022	2.025	2.025
	60	45	0.862	1.198	1.632	1.939	2.16	2.34	2.433	2.513	2.557
EVR 40	60	25	1.05	1.454	1.946	2.238	2.406	2.471	2.471	2.471	2.471
	60	35	1.195	1.657	2.245	2.635	2.897	3.068	3.161	3.166	3.166
	60	45	1.348	1.873	2.55	3.03	3.384	3.65	3.801	3.926	3.995

An increase in hot gas temperature t_h of 10 K reduces valve capacity approx. 2% and vice versa.

Design

EVR 10 (NC)

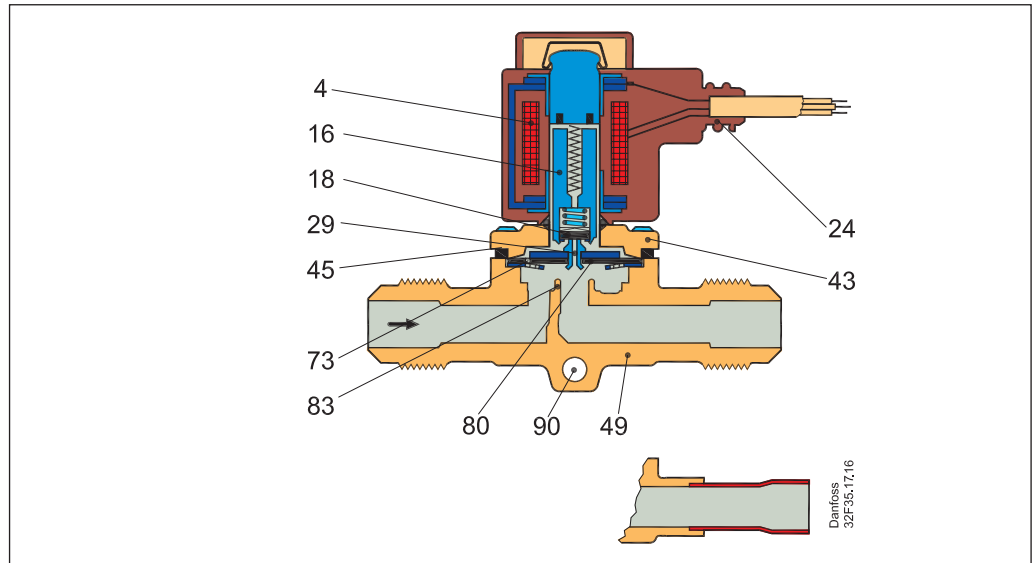

EVR 2 (NC)

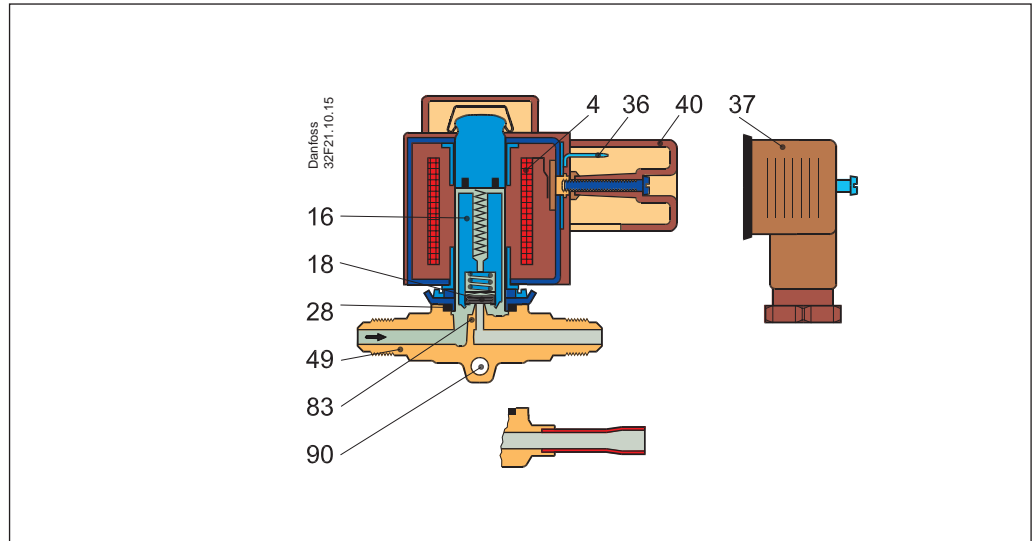

- 4. Coil
- 16. Armature
- 18. Valve plate/
Pilot valve plate
- 20. Earth terminal
- 24. Connection for flexible
steel hose
- 28. Gasket
- 29. Pilot orifice
- 30. O-ring
- 31. Piston ring
- 36. DIN plug
- 37. DIN socket (to DIN 43650)
- 40. Protective cap/
Terminal box
- 43. Valve cover
- 44. O-ring
- 45. Valve cover gasket
- 49. Valve body
- 50. Gasket
- 51. Threaded plug
- 53. Manual operation spindle
- 73. Equalization hole
- 74. Main channel
- 75. Pilot channel
- 76. Compression spring
- 80. Diaphragm/Servo piston
- 83. Valve seat
- 84. Main valve plate
- 90. Mounting hole

EVR 10 (NO)

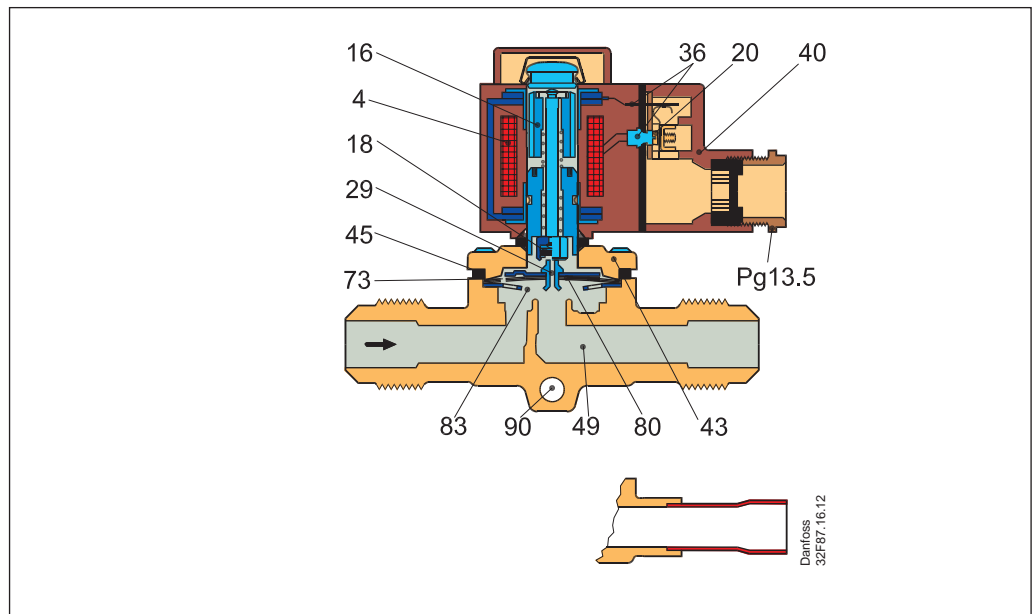

Design
(continued)

EVR 25 (NC)

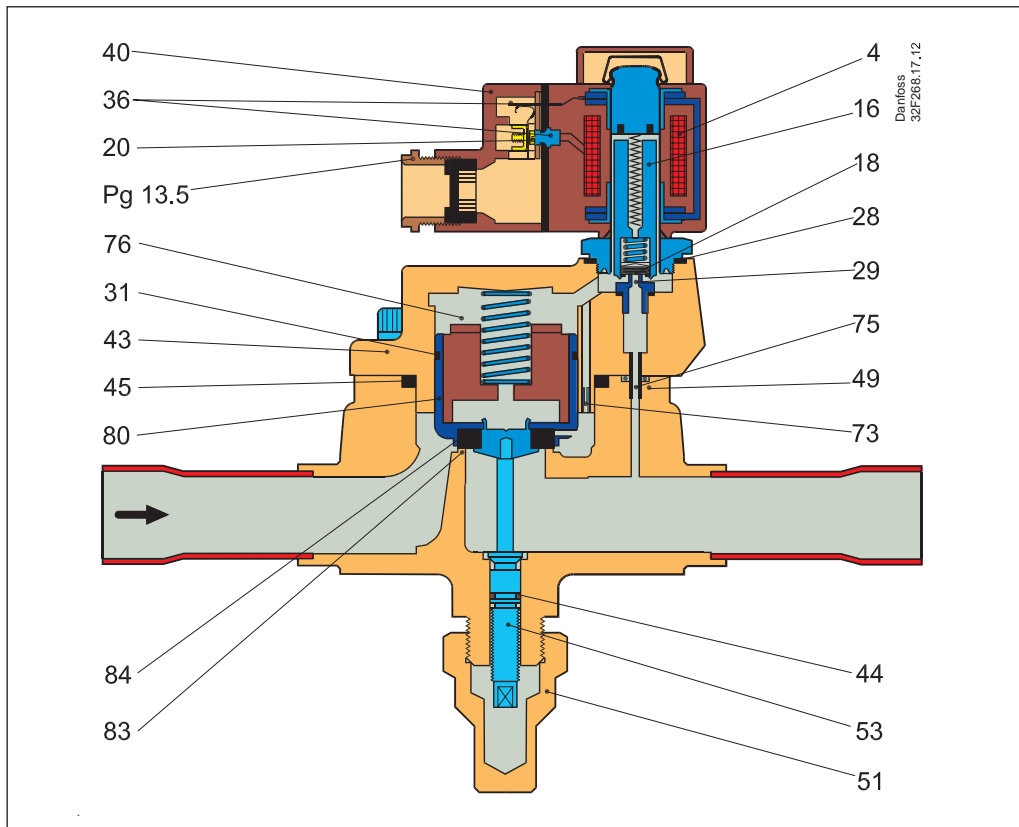

- 4. Coil
- 16. Armature
- 18. Valve plate / Pilot valve plate
- 20. Earth terminal
- 24. Connection for flexible steel hose
- 28. Gasket
- 29. Pilot orifice
- 30. O-ring
- 31. Piston ring
- 36. DIN plug
- 37. DIN socket (to DIN 43650)
- 40. Protective cap / Terminal box
- 43. Valve cover
- 44. O-ring
- 45. Valve cover gasket
- 49. Valve body
- 50. Gasket
- 51. Threaded plug
- 53. Manual operation spindle
- 73. Equalization hole
- 74. Main channel
- 75. Pilot channel
- 76. Compression spring
- 80. Diaphragm / Servo piston
- 83. Valve seat
- 84. Main valve plate
- 90. Mounting hole

EVR 32 and EVR 40 (NC)

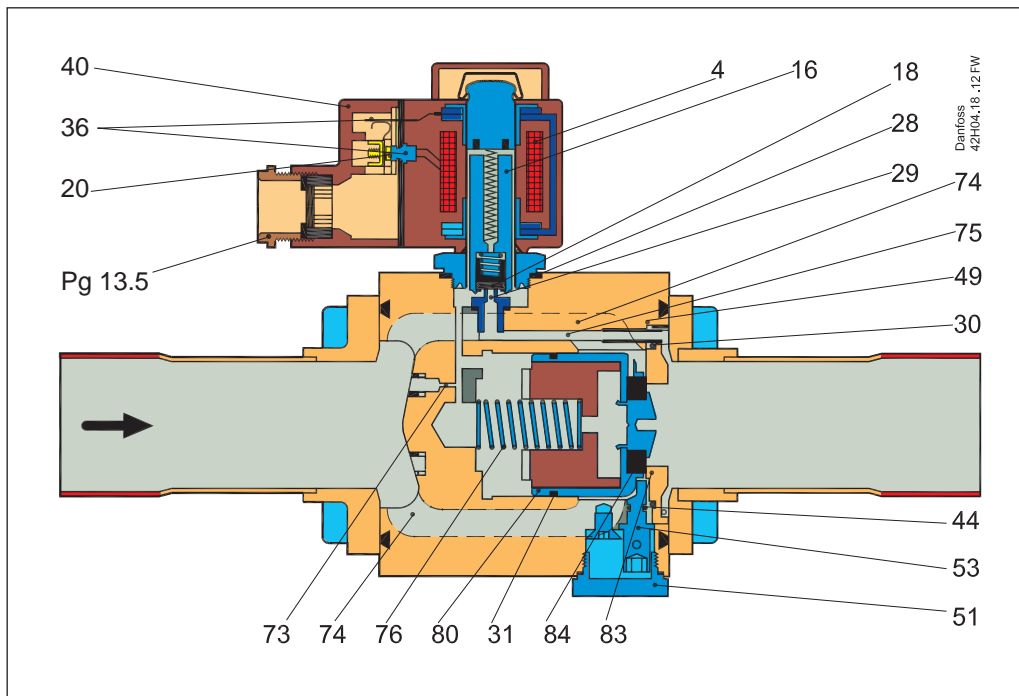

Function

EVR solenoid valves are designed on two different principles:

1. Direct operation
2. Servo operation

1. Direct operation

EVR 2 – 3 are direct operated. The valves open directly for full flow when the armature (16) moves up into the magnetic field of the coil.

This means that the valves operate with a minimum differential pressure of 0 bar.

The valve plate (18) is fitted directly on the armature (16).

Inlet pressure acts from above on the armature and the valve plate. Thus, inlet pressure and spring force act to close the valve when the coil is currentless.

2. Servo operation

EVR 6 – 22 are servo operated with a "floating" diaphragm (80). The pilot orifice (29) of stainless steel is placed in the centre of the diaphragm. The pilot valve plate (18) is fitted directly to the armature (16). When the coil is currentless, the main orifice and pilot orifice are closed. The pilot orifice and main orifice are held closed by the armature spring force and the differential pressure between inlet and outlet sides.

When current is applied to the coil the armature is drawn up into the magnetic field and opens the pilot orifice. This relieves the pressure above the diaphragm, i.e. the space above the diaphragm becomes connected to the outlet side of the valve.

The differential pressure between inlet and outlet sides then presses the diaphragm away from the main orifice and opens it for full flow. Therefore a certain minimum differential pressure is necessary to open the valve and keep it open. For EVR 6 – 22 valves this differential pressure is 0.05 bar.

When current is switched off, the pilot orifice closes. Via the equalization holes (73) in the diaphragm, the pressure above the diaphragm then rises to the same value as the inlet pressure and the diaphragm closes the main orifice.

EVR 25, EVR 32 and EVR 40 are servo operated piston valves. The valves are closed with currentless coil. The servo piston (80) with main valve plate (84) closes against the valve seat (83) by means of the differential pressure between inlet and outlet side of the valve and the force of the compression spring (76). When current to the coil is switched on, the pilot orifice (29) opens. This relieves the pressure on the piston spring side of the valve. The differential pressure will then open the valve. The minimum differential pressure needed for full opening of the valves is 0.2 bar. EVR (NO) has the opposite function to EVR (NC), i.e. it is open with de-energised coil.

EVR (NO) is available with servo operation only.

Material specifications

EVR 2 – 25

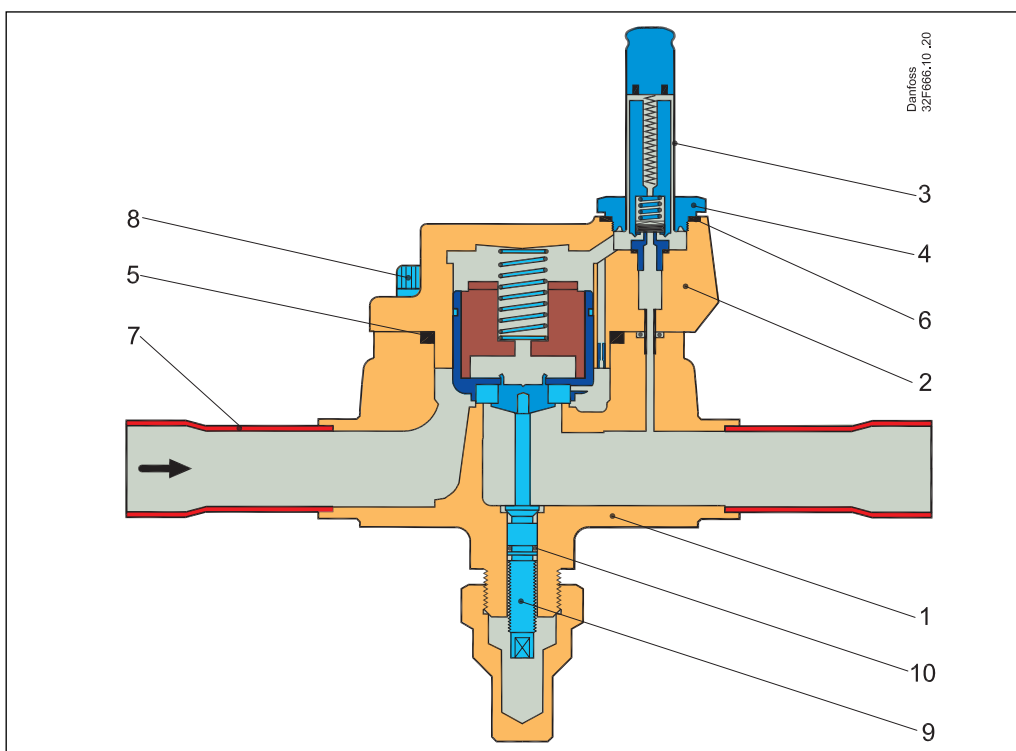
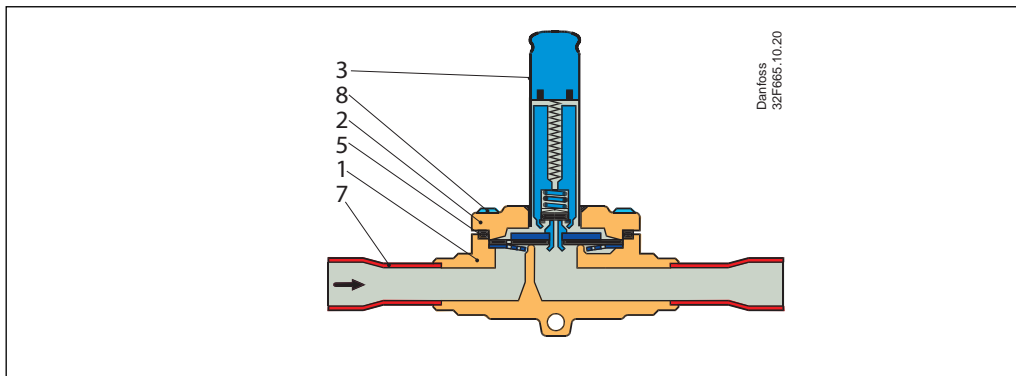

No.	Description	Solenoid valves type	Material	Analysis	Mat.no.	W.no.	Standard	
							DIN	EN
1	Valve body	EVR 2 – 25	Brass	CuZn40Pb2	CW617N	2.0402	17672-1	12165
2	Cover	EVR 2 – 6	Stainless steel	X5 CrNi18-10	—	1.4301	—	10088
		EVR 10 – 22	Brass	CuZn40Pb2	CW617N	2.0402	17672-1	12165
		EVR 25	Cast iron	EN-GJS-400-18-LT	EN-JS1025	—	—	1563
3	Armature tube	EVR 2 – 25	Stainless steel	X2 CrNi19-11	—	1.4306	—	10088
4	Armature tube nut	EVR 25	Stainless steel	X8 CrNiS 18-9	—	1.4305	—	10088
5	Gasket	EVR 2 – 25	Rubber	Cr	—	—	—	—
6	Gasket	EVR 25	Al. gasket	Al 99.5	—	3.0255	—	10210
7	Solder tube	EVR 25	Copper	SF-Cu	CW024A	2.0090	1787	12449
8	Screws	EVR 2 – 25	Stainless steel	A2-70	—	—	3506	—
9	Spindle for man. operat.	EVR 25	Stainless steel	X8 CrNiS 18-9	—	1.4305	—	10088
10	Gasket	EVR 25	Rubber	Cr	—	—	—	—

Material specifications
(continued)

EVR 32 – 40

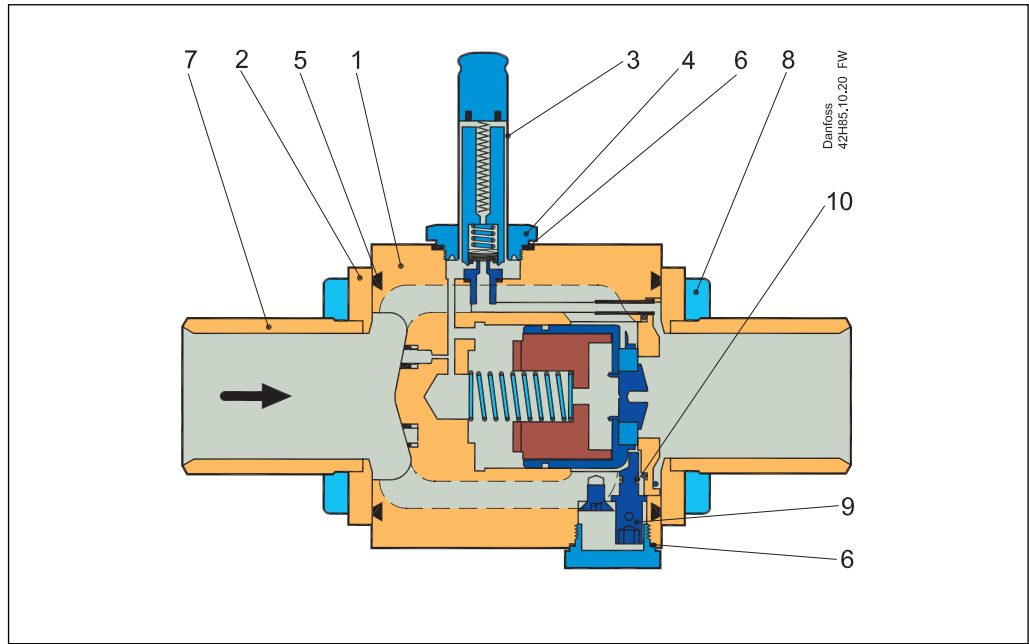

No.	Description	Solenoid valves type	Material	Analysis	Mat.no.	W.no.	Standard	
							DIN	EN
1	Valve body	EVR 32/40	Cast Iron	EN-GJS-400-18-LT	EN-JS1025	—	—	1563
2	Cover	EVR 32/40	Brass	CuZn40Pb2	CW617N	2.0402	—	12165
3	Armature tube	EVR 32/40	Stainless steel	X2 CrNi19-11	—	1.4306	—	10088
4	Armature tube nut	EVR 32/40	Stainless steel	X8 CrNiS 18-9	—	1.4305	—	10088
5	Gasket	EVR 32/40	Rubber	Cr	—	—	—	—
6	Gasket	EVR 32/40	Al. gasket	Al 99.5	—	3.0255	—	10210
7	Solder tube	EVR 32/40	Copper	SF.Cu	CW024A	2.0090	1787	12449
8	Screws	EVR 32/40	Stainless steel	A2-70	—	—	3506	—
9	Spindle for. man. operation	EVR 32/40	Stainless steel	X8 CrNiS 18-9	—	1.4305	—	10088

Dimensions [mm] and weights [kg]

With cable connection coil

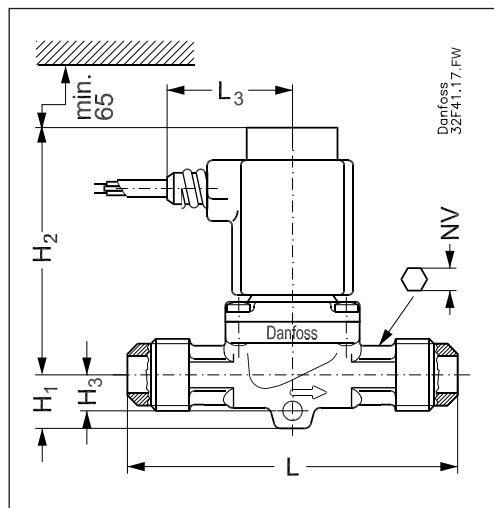

With DIN plugs coil

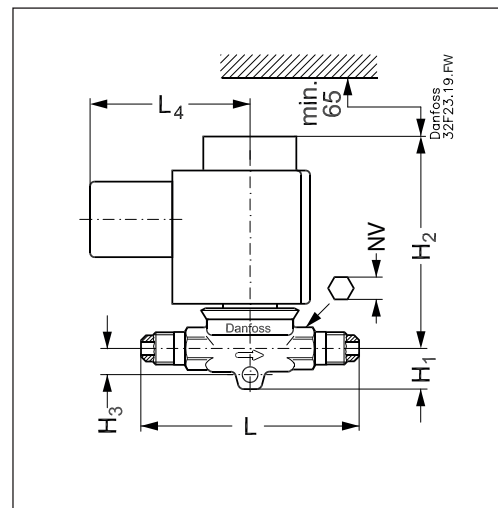

With terminal box coil

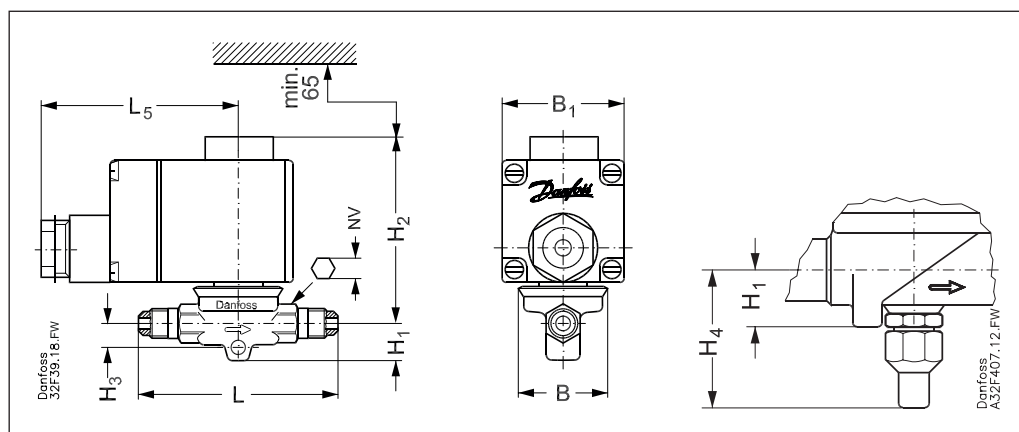

Net weight of coil
 10 W: approx. 0.3 kg
 12 and 20 W: approx. 0.5 kg

EVR (NC) 2 – 15, EVR 6 – 15 (NO), flare connection

Type	Connection Flare		H ₁	H ₂	H ₃	H ₄	L	L ₃	L ₄	NV	L ₅ max.		B	B ₁ max.	Net weight with coil
	[in.]	[mm]									10 W	12/20 W			
EVR 2	1/4	6	14	73	9	—	75	45	54	13	75	85	33	68	0.5
EVR 3	1/4	6	14	73	9	—	75	45	54	13	75	85	33	68	0.5
	3/8	10	14	73	9	—	75	45	54	13	75	85	33	68	0.5
EVR 6	3/8	10	14	78	10	—	82	45	54	14	75	85	33	68	0.6
	1/2	12	14	78	10	—	88	45	54	14	75	85	33	68	0.6
EVR 10	1/2	12	16	79	11	—	103	45	54	16	75	85	46	68	0.8
	5/8	16	16	79	11	—	110	45	54	16	75	85	46	68	0.8
EVR 15	5/8	16	19	86	—	49	131	45	54	24	75	85	56	68	1.0

**Dimensions [mm]
and weights [kg]**
(continued)

With cable connection coil

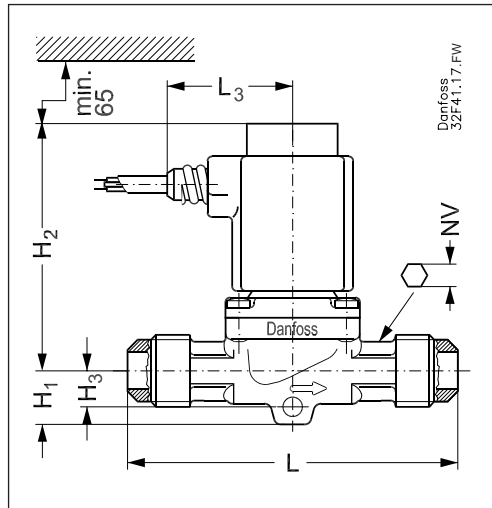

With DIN plugs coil

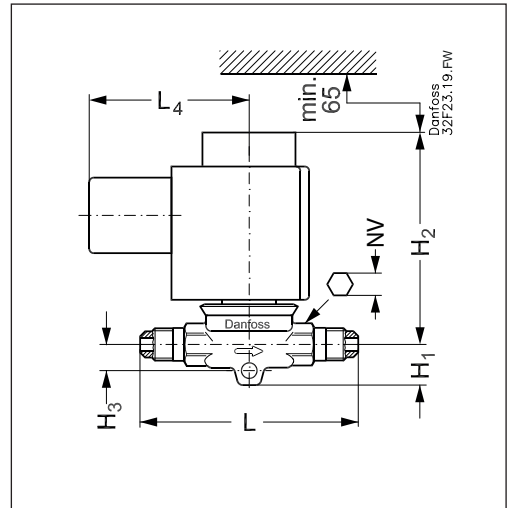

With terminal box coil

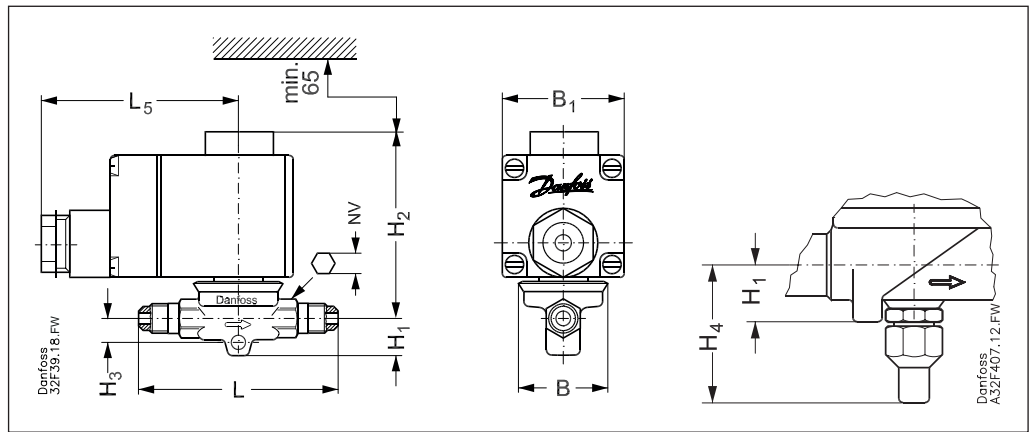

Net weight of coil

10 W: approx. 0.3 kg

12 and 20 W: approx. 0.5 kg

EVR (NC) 2 – 22, EVR 6 – 22 (NO), solder connection

Type	Connection Solder		H ₁	H ₂	H ₃	H ₄	L	L ₂	L ₃	L ₄	L ₅ max.		B	B ₁ max.	Net weight with coil
	[in.]	[mm]									10 W	12/20 W			
EVR 2	1/4	6	14	73	9	—	102	7	45	54	75	85	33	68	0.5
EVR 3	1/4	6	14	73	9	—	102	7	45	54	75	85	33	68	0.6
	3/8	10	14	73	9	—	117	9	45	54	75	85	33	68	0.6
EVR 6	3/8	10	14	78	10	—	111	9	45	54	75	85	33	68	0.6
	1/2	12	14	78	10	—	127	10	45	54	75	85	33	68	0.6
EVR 10	1/2	12	16	79	11	—	127	10	45	54	75	85	46	68	0.7
	5/8	16	16	79	11	—	160	12	45	54	75	85	46	68	0.7
EVR 15	5/8	16	19	86	—	49	176	12	45	54	75	85	56	68	1.0
	7/8	22	19	86	—	—	176	17	45	54	75	85	56	68	1.0
EVR 20	7/8	22	20	90	—	53	191	17	45	54	75	85	72	68	1.5
	1 1/8	28	20	90	—	—	214	22	45	54	75	85	72	68	1.5
EVR 22	1 3/8	35	20	90	—	—	281	25	45	54	75	85	72	68	1.5

**Dimensions [mm]
and weights [kg]**
(continued)

EVR 25 with terminal box coil

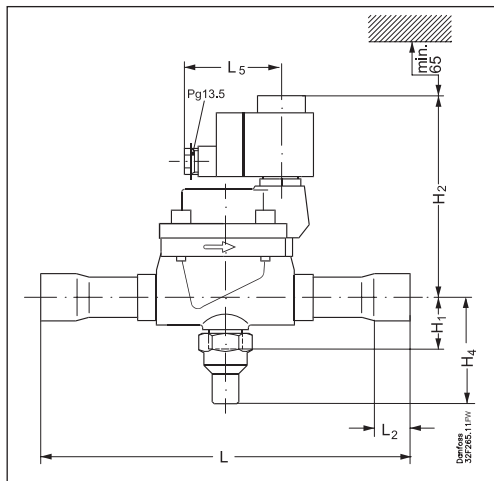

EVR 32 and EVR 40 terminal box

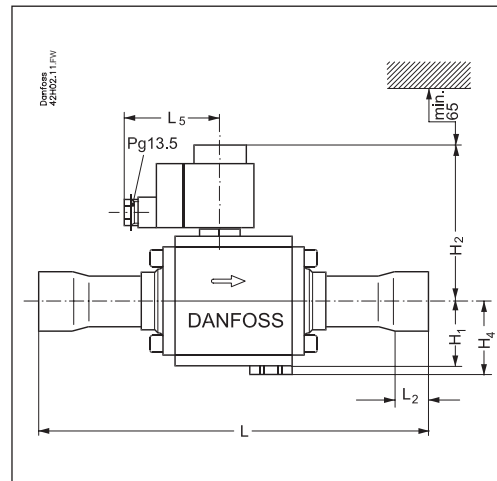

EVR 25

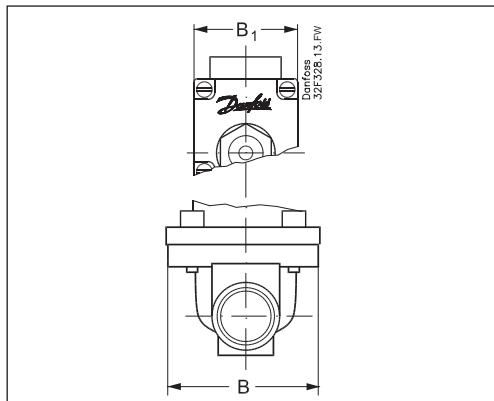

EVR 32 and EVR 40

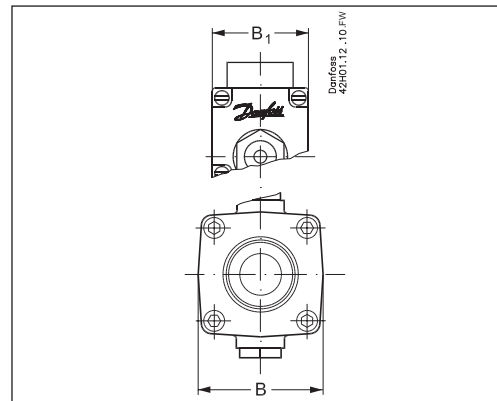

Coil with cable

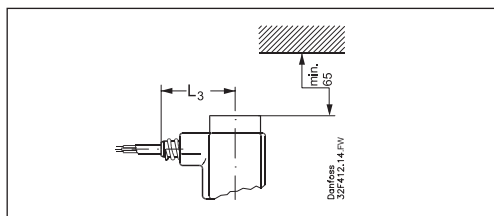

Coil with DIN plugs

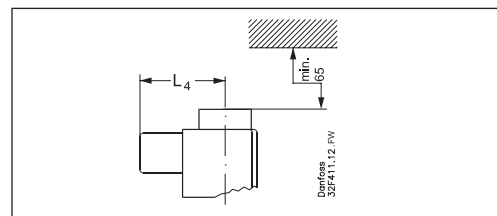

Net weight of coil

10 W: approx. 0.3 kg
12 and 20 W: approx. 0.5 kg

EVR (NC) 25, EVR 32 og EVR 40, solder connection

Type	Connection Solder		H ₁	H ₂	H ₄	L	L ₂	Coil with cable connection L ₃	Coil with DIN connection L ₄	Coil with terminal box L ₅ max.		B	B ₁ max.	Net weight with coil
	[in.]	[mm]								10 W	12/20 W			
EVR 25	1 1/8	28	38	138	72	256	22	45	54	75	85	95	68	3.0
	1 3/8	35	38	138	72	281	25	45	54	75	85	95	68	3.3
EVR 32	1 3/8	35	47	111	53	281	25	45	54	75	85	80	68	4.5
	1 5/8	42	47	111	53	281	29	45	54	75	85	80	68	4.6
EVR 40	1 5/8	42	47	111	53	281	29	45	54	75	85	80	68	4.6
	2 1/8	54	47	111	53	281	34	45	54	75	85	80	68	4.6

**Dimensions [mm]
and weights [kg]**
(continued)

With terminal box coil

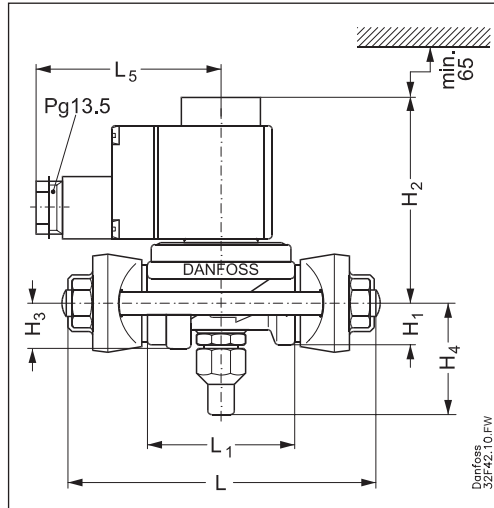

Coil with cable

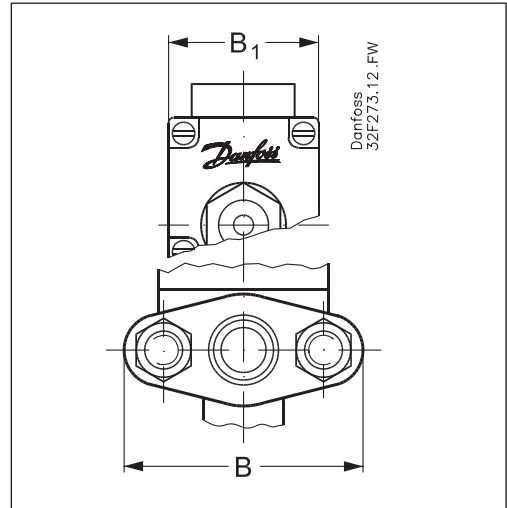

Coil with DIN plugs

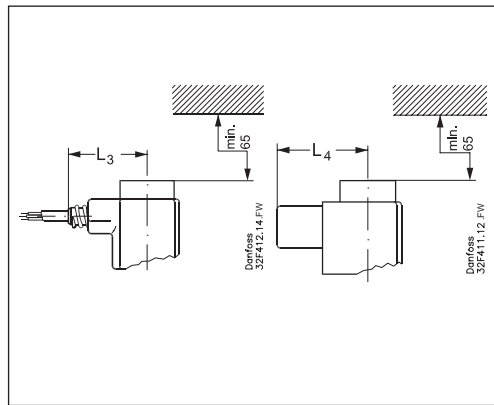

Net weight of coil
10 W: approx. 0.3 kg
12 and 20 W: approx. 0.5 kg

Weight of flange set
For EVR 15: 0.6 kg
For EVR 20: 0.9 kg

EVR (NC) 15 and EVR 20, flange connection

Type	H ₁	H ₂	H ₃	H ₄	L	L ₁	Coil with cable connection L ₃	Coil with DIN connection L ₄	Coil with terminal box L ₅ max.		B	B ₁ max.	Net weight with coil excl. flanges
									10 W	12/20 W			
EVR 15	19	86	19	49	125	68	45	54	75	85	80	68	1.2
EVR 20	20	90	21	53	155	85	45	54	75	85	96	68	1.7

Danfoss can accept no responsibility for possible errors in catalogues, brochures and other printed material. Danfoss reserves the right to alter its products without notice. This also applies to products already on order provided that such alterations can be made without consequential changes being necessary in specifications already agreed. All trademarks in this material are property of the respective companies. Danfoss and the Danfoss logotype are trademarks of Danfoss A/S. All rights reserved.